

SafeLine *M* N2-W4-cc3

# Tube formed Median Barrier

## Installation manual



05.03.19



**Vik:**  
Elvagata 20  
6893 Vik i Sogn

**Tlf: +47 57 69 86 50**  
[firmapost@vikorsta.no](mailto:firmapost@vikorsta.no)

**Ørsta:**  
Strandgata 59  
6150 Ørsta

**Tlf: +47 70 04 70 00**  
[firmapost@vikorsta.no](mailto:firmapost@vikorsta.no)

Saferoad Sverige AB

**Köping:**  
Volvogatan 2  
731 36 KÖPING

**Tlf: +46 221 297 00**  
[info@saferoad.se](mailto:info@saferoad.se)

## Index

1. Important .....	3
2. Description.....	3
3. Level of performance.....	3
4. Installing.....	4
4.1 Soil and placement .....	5
4.2 Installing the posts .....	5
4.3 Installing the profiles/tubes/ longitudinal elements.....	6
4.4 After installation.....	7
5. Maintenance .....	7
5.1 Cleaning .....	7
6. Bolts and fasteners .....	7
7. Marking .....	7
8. Drawings.....	8
8.1 SafeLine-M N2-W4-cc3m.....	8
8.2 post.....	9
8.3 Fixing elements.....	10
8.4 Longitudinal beams .....	17
8.5 Alternative post placement/-fixing (c/c 3m) .....	19

Copyright© , Vik Ørsta A/S

All right reserved. No part of this book may be reproduced or transmitted in any form or by any means, digital or permission in writing by Vik Ørsta A/S.

All statements and technical information are based on results obtained under typical conditions. It is the responsibility of the recipient to clarify with us that the information is appropriate for the specific use intended by the recipient. Please check with our Customer Service for further information.

## 1. Important

Proper installation and repair are essential to ensure the systems maximum performance.

## 2. Description

The SafeLine-M is a steel road restraint system that is designed to enhance safety on the roads.

The system has successfully been tested according to classes N2, described in EN 1317-2.

The system is based on C-formed steel posts with post distance of 3 meters and a longitudinal C-formed elliptic steel tubes/profiles, placed on top of the posts.

In a collision, the system is designed to lead the vehicle back on the road.

The bolts are an important part of the system function and this manual should be read carefully before installation is started.

## 3. Level of performance

According to EN-1317

Post distance	Containment level	Working width	Dynamic deflection	Impact severity level	System height [mm]
3 m	N2	W4 (1,3m)	1,0m	A	600

4. Installing

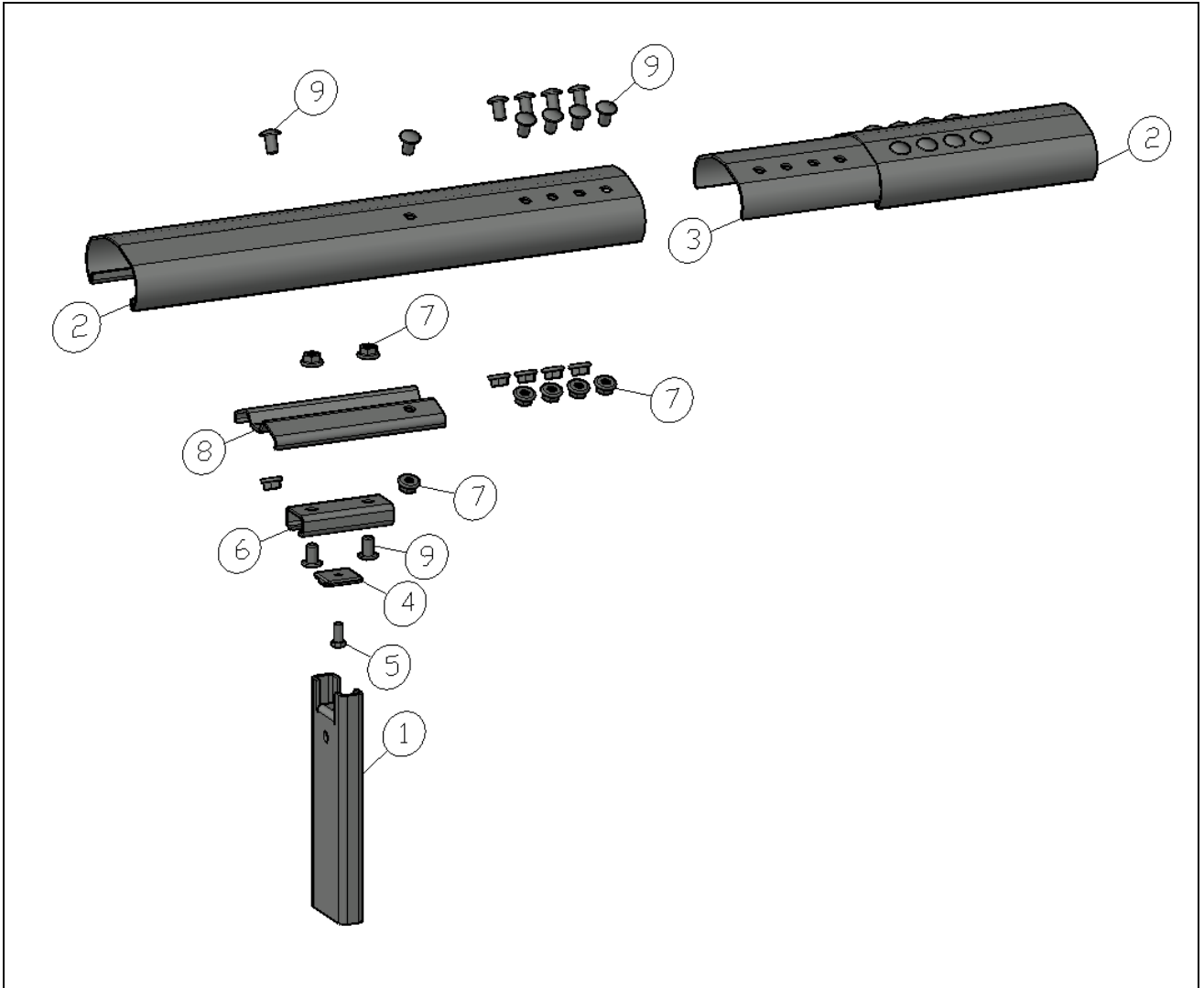

Pos. no.	Description/Item	Quality	Drawing
1	Post C-120 (120x40x25x5), length 1300 mm	S355	CT-010
2	Oval open top profile, length 6000 mm	S420	CT-025
3	Joint plate	S420	CT-014
4	Connector plate, T-washer	S355	CT-013
5	Bolt M12x25 VZN	4.6	
6	Mini C 65	S355	CT-011
7	Flenge nut M16	8	
8	Top plate	S355	CT-012
9	Bolt M16x30 with rounded head	8.8	

#### 4.1 Soil and placement

The soil where the barrier is placed should be of sufficient quality to ensure the guardrails function.

The posts should bend and not break up true the soil or be pulled up when the barrier is hit.

#### 4.2 Installing the posts

The posts should be installed with a distance of 3 meters. Every second with front / rear, as shown in the figure below.

The holes for the posts should normally be pre-drilled or pre-rammed before installing the post. They should be drilled to the correct level or deeper, to ensure that there is no need to ram the posts after they are placed.

After alignment and height adjustment, parts of the hole around the post should be filled with gravel to lock the post in the correct position.

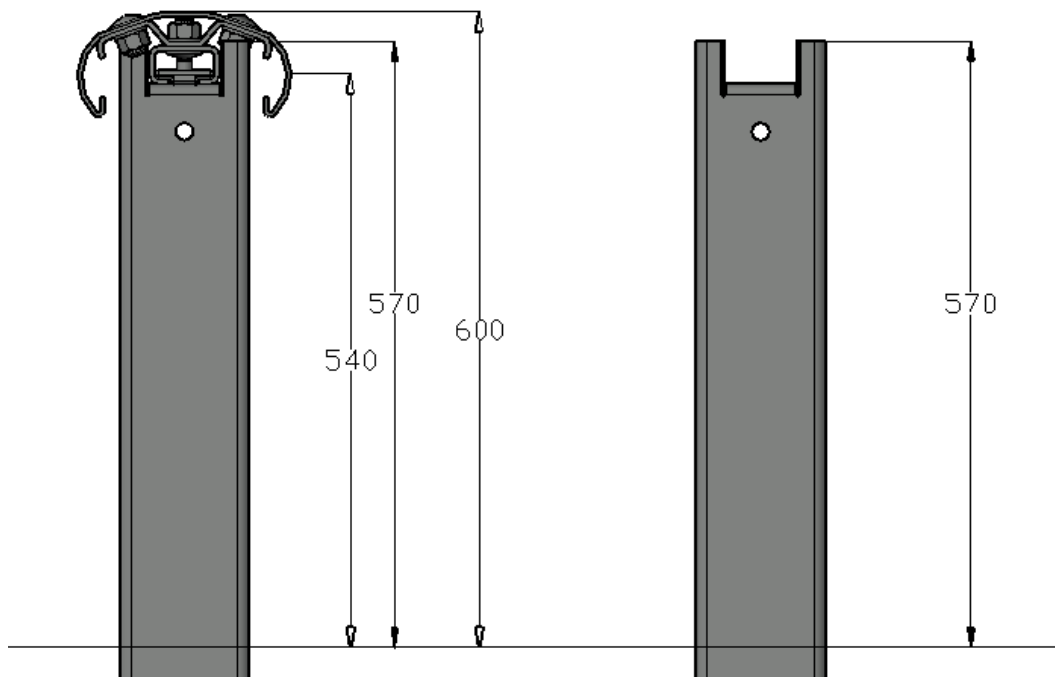

*Hight of the post.*

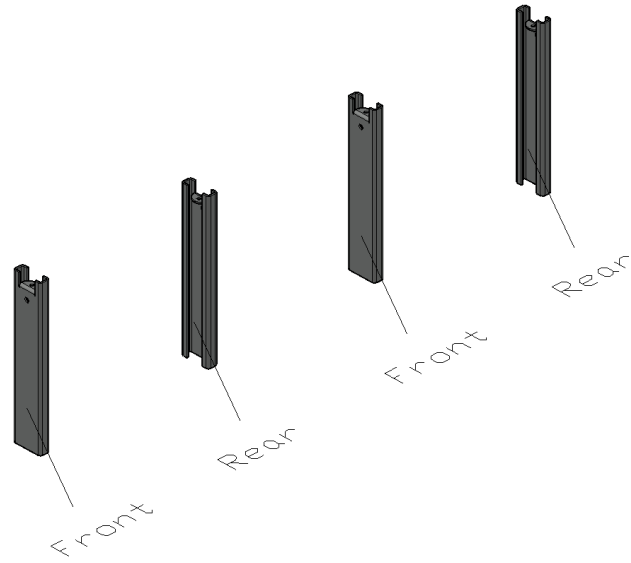

*Direction for the posts.*

#### **4.3 Installing the profiles/tubes/ longitudinal elements**

For details regarding connection between post to profile and profile to profile, and joining of longitudinal profile, see chapter 8. Drawings.

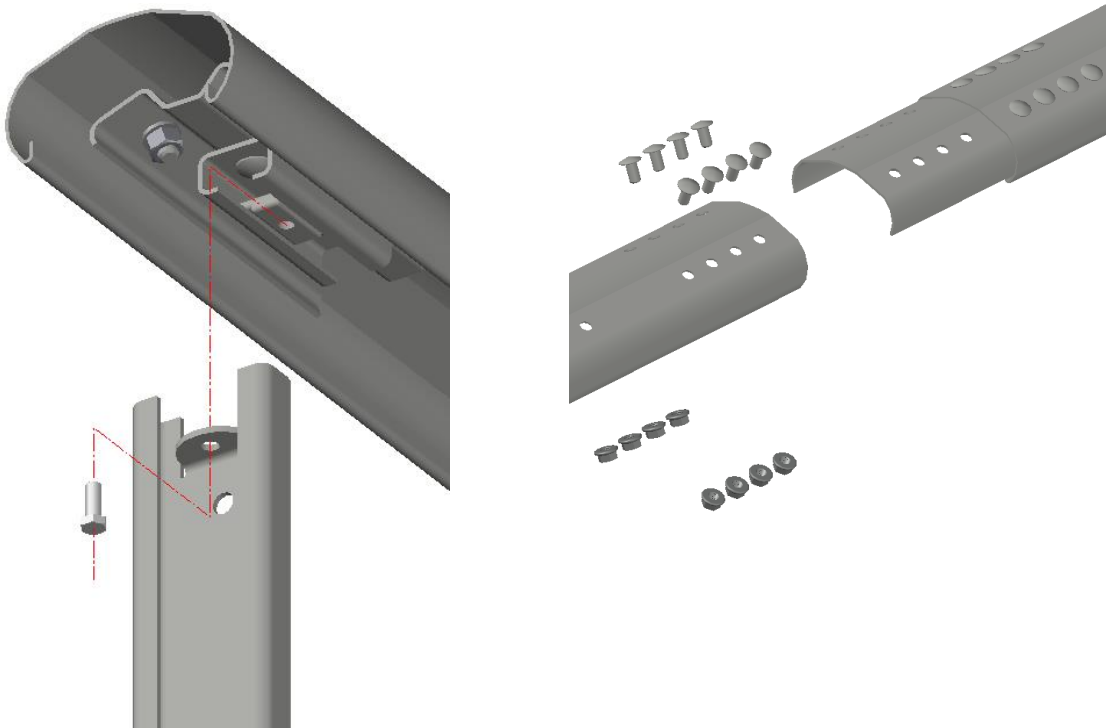

#### 4.4 After installation

When the guardrail is installed and adjusted, the holes around the post should be fully refilled.

### 5. Maintenance

There are no general inspections intervals for this guardrail itself. Inspections intervals have to be determined based on local factors such as volume of traffic, risk of damage, climate etc.



The guard rail should be inspected regularly and if displaced or damaged, it should be adjusted and repaired.

All damaged profiles should be replaced with new when repaired.

#### 5.1 Cleaning

Cleaning can be done with water and any type of Ph neutral detergent.

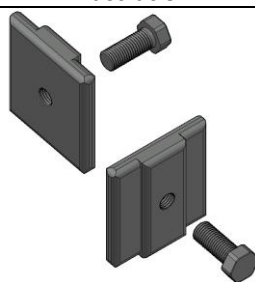
### 6. Bolts and fasteners

Art. no.	Description	Amount	Illustration
	<b>Fastening bolt M12x25 mm 4.6 (hop dip galvanized)</b>		
	xxxxx Bolt M12x25, DIN933	1	
	xxxxx Washer M12, 60x55x12mm	1	
	Tightening torque: Tighten down firmly 4.6: max. 35 Nm 8.8: max. 85 Nm		
xxxxx	<b>Connecting bolt M16x30 mm 8.8 (hot dip galvanized)</b>		
	xxxxx Bolt M16x30	1	
	692316000 Flange nut M 16	1	
	Tightening torque: Tighten down firmly max. 215 Nm		

**Note:** Please check that all bolts/fasteners are placed correct and all bolts-washer-nuts-connections are normally/proper fastened/tighten.

### 7. Marking

If everything is done and installed according to this installation manual, the guardrail can be marked with the CE-mark. This mark shall be placed at the end (the starting end) of the installed guardrail.



8.2 post

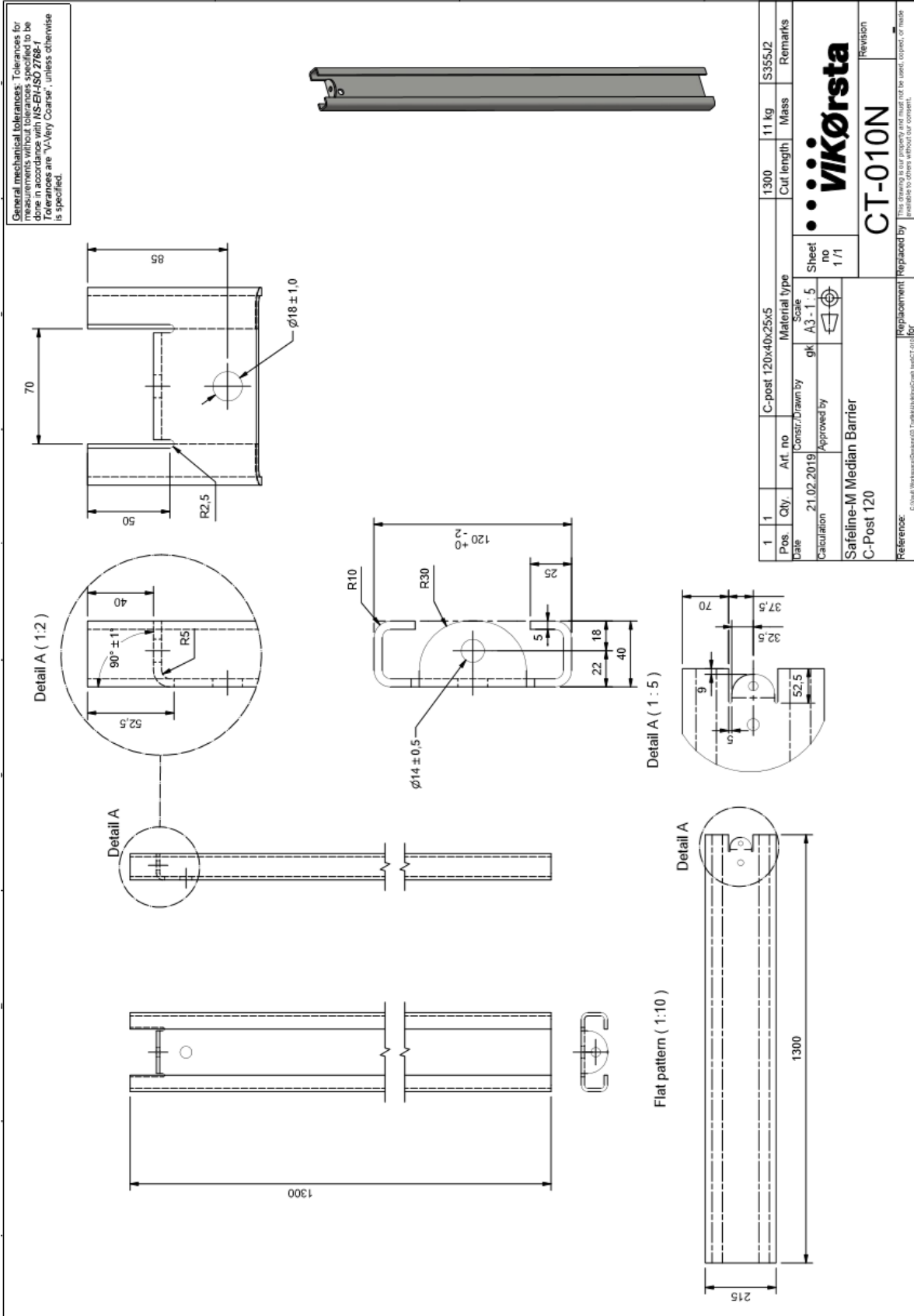

8.3 Fixing elements

General mechanical tolerances: Tolerances for measurements without tolerance are assumed to be according to EN ISO 2768. Tolerances are "Machinery Castair", unless otherwise is specified.

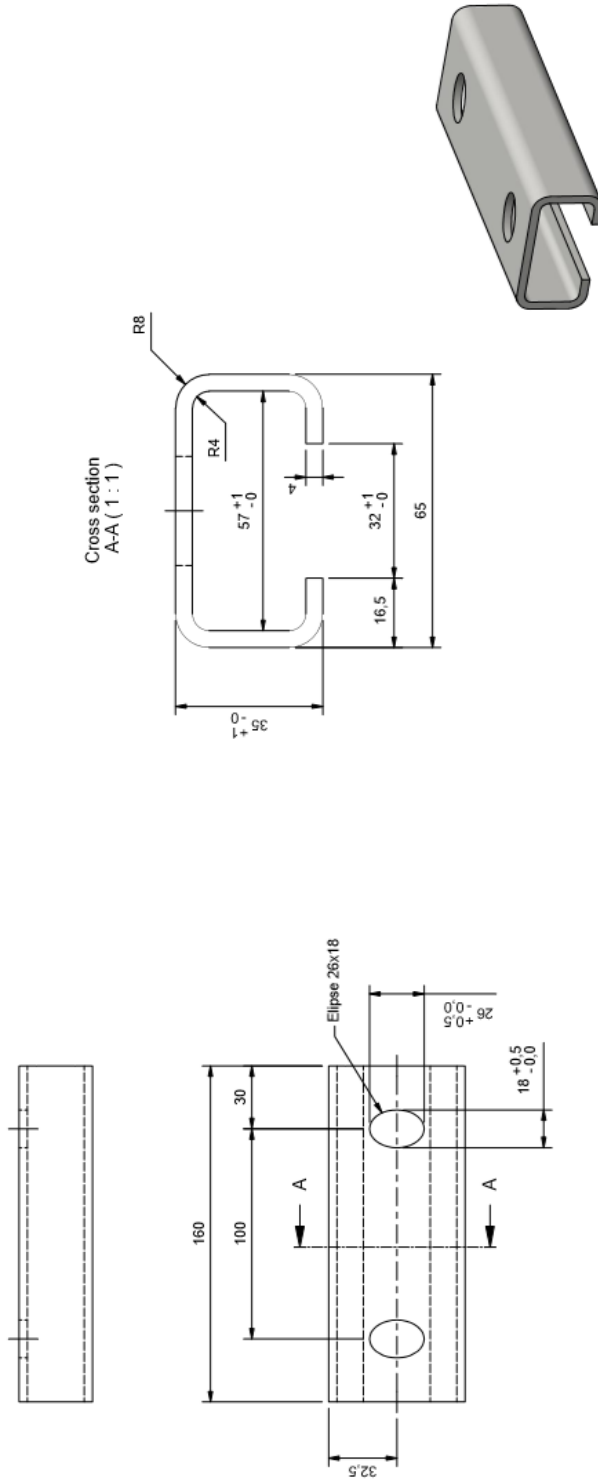

1					C-profile 65x35x4			0,7 kg	S355J2	
Pos.	Qty.	Art. no.	Material type	Remarks						
Date	21.02.2019	Const./Drawn by	SSA							
Calculation		Approved by	gk A3-1-2	Sheet no 1/1						
Safeline-M Median Barrier										
Mini C for oval profile 200										
Reference: C:\bvt\material\65x35x4\65x35x4\65x35x4.dwg					Replacement		Repaired by		Revision	
					CT-011N					

General mechanical tolerances: Tolerances for measurements without tolerances specified to be done in accordance with EN ISO 2768-1. Tolerances are V-Very Coarse, unless otherwise is specified.

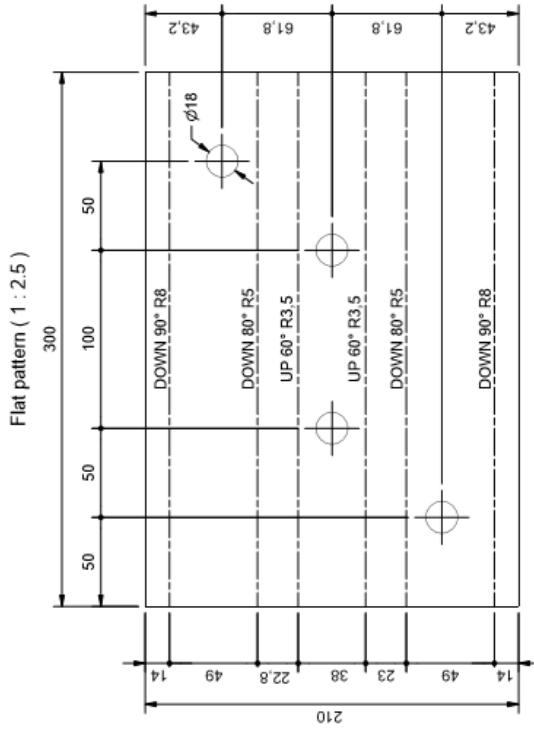
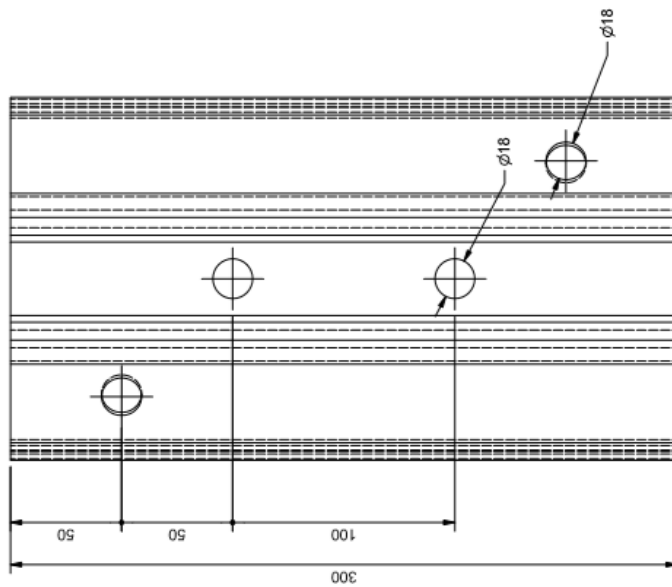
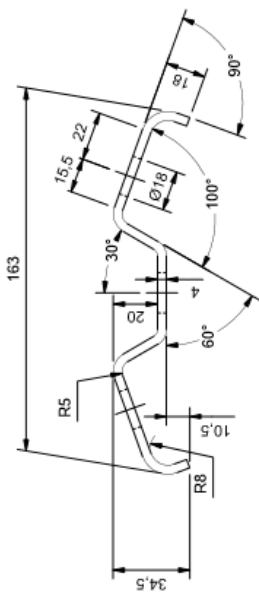
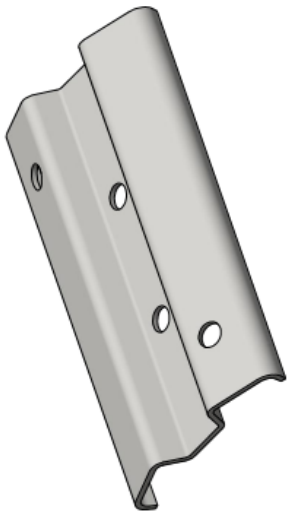

1	1	Steel plate t=4 mm	2 kg	S355 J2	Remarks
Pos.	Qty.	Art. no	Cut length	Mass	
Date	21.02.2019	Constr./Drawn by	Scale	A3 - 1:2	Sheet no
Calculation	Approved by	gk	Material type	gk	1/1
Safeline-M Median Barrier		Replacement		Replaced by	
Top plate		CT-012N		Revision	
Reference: <small>C:\Users\Wakker\Documents\Twekubak\Gema\InstCT-012N</small>					



CT-012N

Revision

This drawing is our property and must not be used, copied, or made available to others without our consent.

*John A. Hystad*



General mechanical tolerances: Tolerances for dimensions are specified to be done in accordance with EN-ISO 2768-1. Tolerances are "A=Very Coarse", unless otherwise is specified.

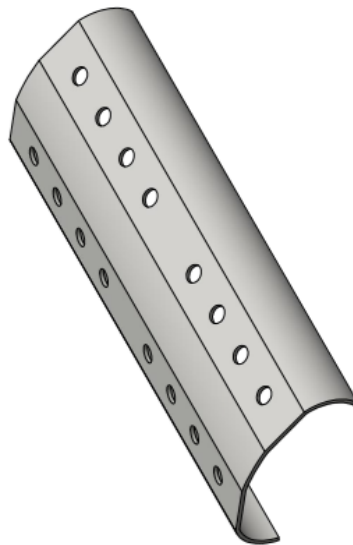
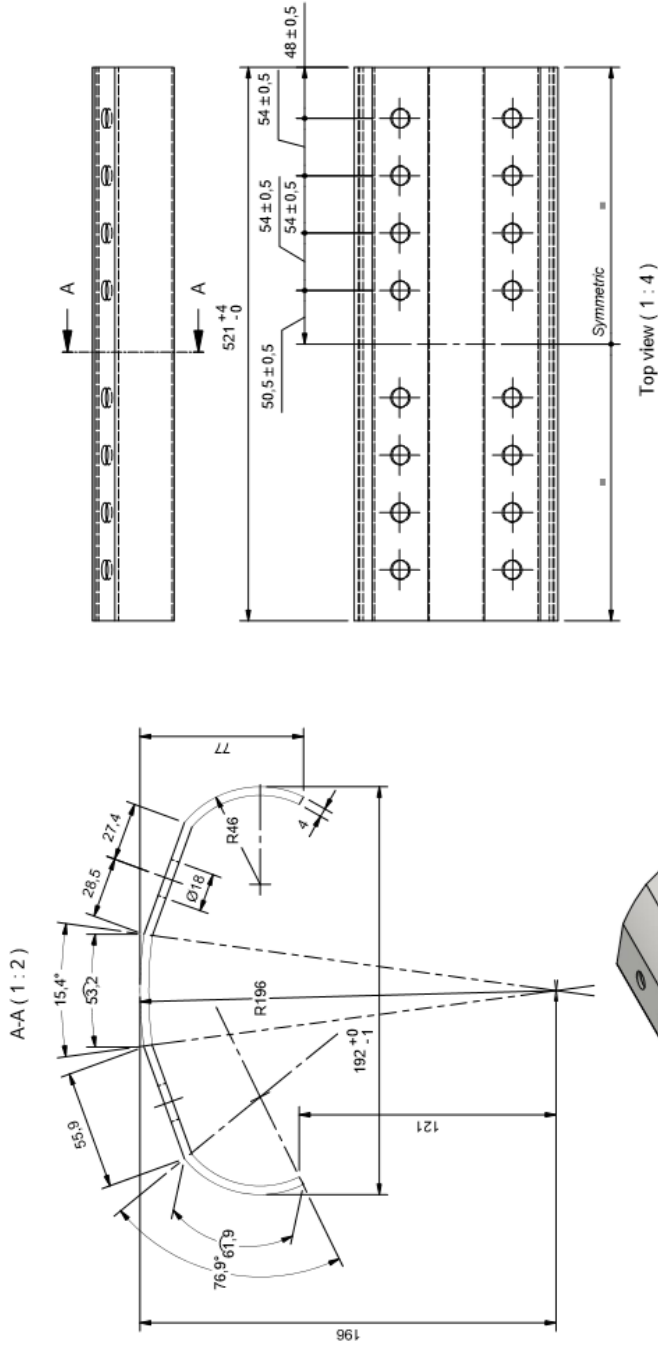

1	1	Steel plate t=4.0	Material type	4.5 kg	S420 acc. to EN10025	Remarks
Pos.	Qty.	Art. no	Constr./Drawn by	Cut length	Mass	
Date	21.02.2019	gk	Scale	A3-1:4	Sheet no	1/1
Calculation	Approved by					
Safeline-M Median Barrier Joint plate			<b>VIKØRSTA</b>			
			CT-014N			
Reference: C:\Users\Bjorn\Documents\Bjorn\SafeLine\SafeLine\CT-014			Replacement			
			Replaced by			
			This drawing is our property and must not be used, copied, or made available to others without our consent.			



General mechanical tolerances: Tolerances for mechanical dimensions are specified to be done in accordance with EN-ISO 2768-f. Tolerances are "Average Coarse", unless otherwise is specified.



Top view ( 1 : 4 )

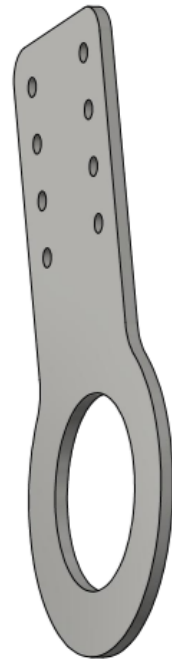
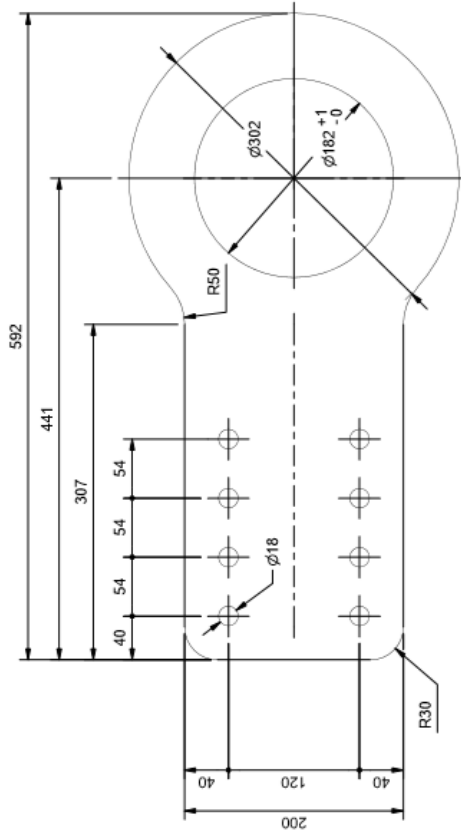

1	1	Steel plate l=12	Material type	9,8 kg	S355 J2	Remarks
Pos	Qty	Art. no	Scale	Cut length	Mass	
Date	21.02.2019	Constr./Drawn by	A3 - 1 - 4			
Calculation	Approved by		Sheet no			
			1 / 1			
Safeline-M Median Barrier						
Anchor spike fixing plate						
Reference: C:\Users\Walter\Documents\Trafikskilte\SafeLine\SafeLine.ctb			Prepared by: <b>CT-018N</b> Revision:			

General mechanical tolerances: Tolerances for measurements without further specification are according to EN ISO 2768. Tolerances are "Average Coarse", unless otherwise is specified.

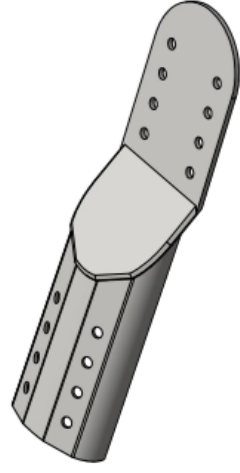
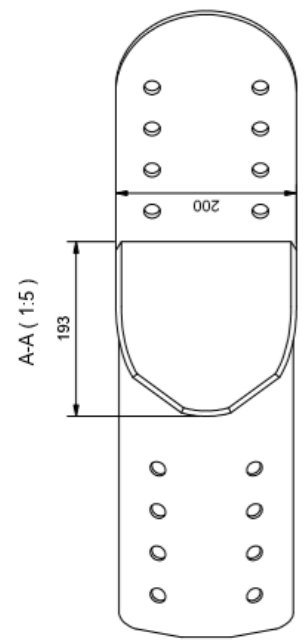
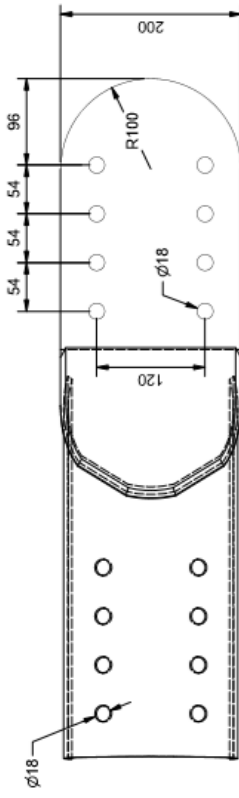
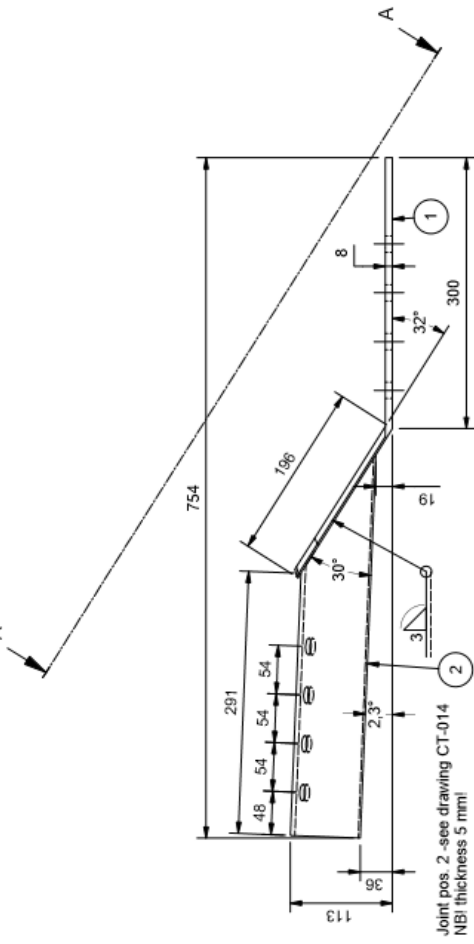

2	1	Joint plate l=5mm	3.6 kg	S355 J2	
1	1	Steel plate l=8mm	5.4 kg	S355 J2	
Pos. Qty.		Art. no	Material type	Cut length	Remarks
Date		Constr. Drawn by	Scale	Sheet	
Calculation		Approved by	A3 - 1:5	no	
				1/1	
Safeline-M Median Barrier Beaver tail plate for anchor spike			 <b>CT-024N</b>		
Reference: E:\vial\Material\2019\02_Tekniske\3000\SafeCT_024					
Replacement by			Revision		

*John Ø. Hystad*

8.4 Longitudinal beams

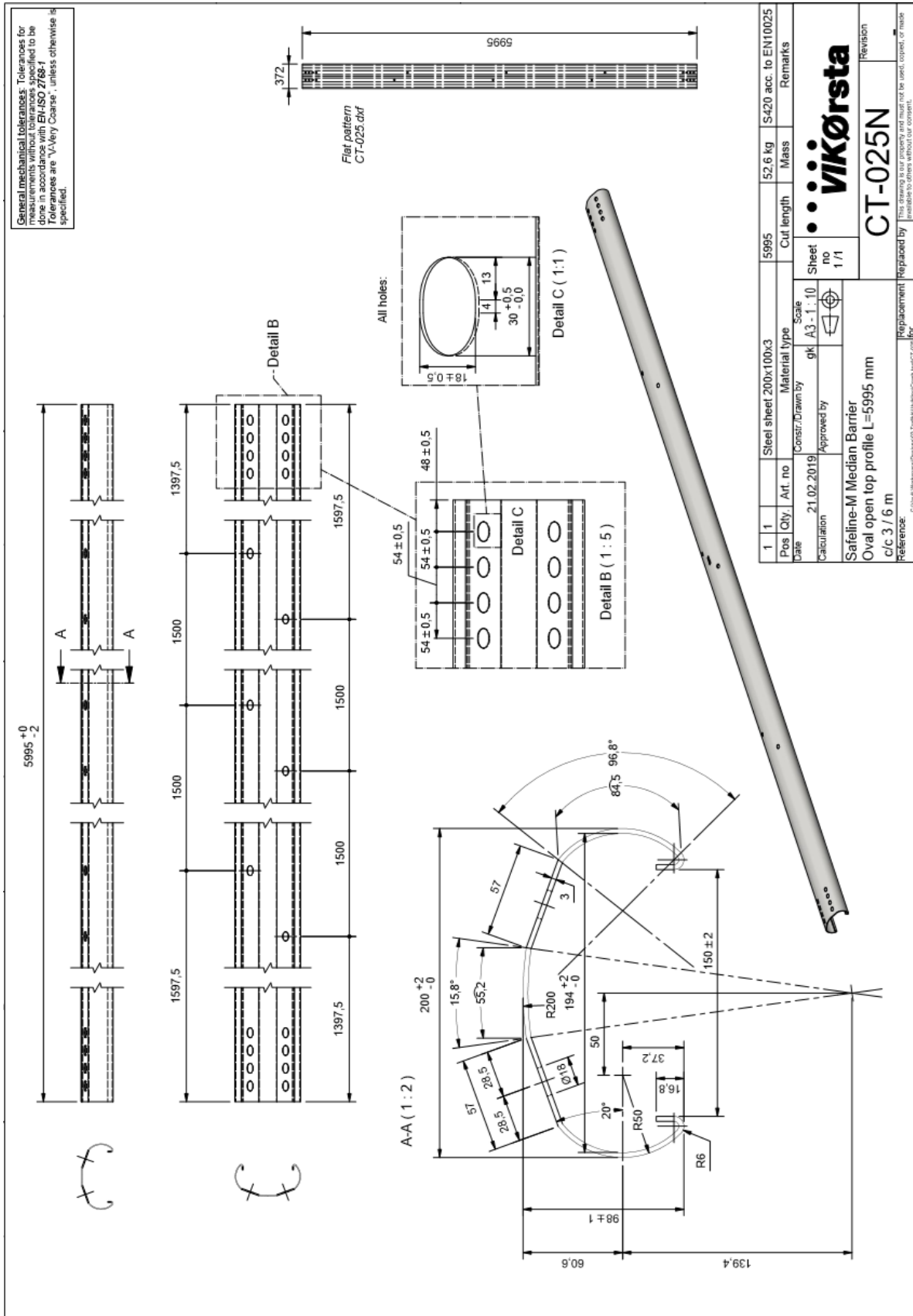



8.5 Alternative post placement/-fixing (c/c 3m)

